



Torque/Pressure Chart

Pump Pressure (P.S.I.)	Tool Output (FT./LBS.)
1000	330
1200	395
1400	460
1600	525
1800	590
2000	655
2200	722
2400	789
2600	856
2800	923
3000	990
3200	1,058
3400	1,126
3600	1,194
3800	1,262
4000	1,330
4200	1,397
4400	1,464
4600	1,531
4800	1,599
5000	1,667
5200	1,734
5400	1,802
5600	1,870
5800	1,938
6000	2,006

*Up*  
**torque**

**THE SHAPE CHANGER**

**SQ SQUARE DRIVE TORQUE WRENCH**

# SQ

## UNI-SWIVEL SQUARE DRIVE HYDRAULIC TORQUE WRENCH THE WRENCH WITH CURVES

THE HYDRAULIC WRENCH WITH A SHAPE LIKE NO OTHER ... FOR A REASON! EVERY ANGLE. EVERY CURVE. EVERY FEATURE ON THE SQ SERIES IS DESIGNED WITH A PURPOSE. FROM A BLANK SHEET OF PAPER, WE TOOK 20 YEARS OF HYDRAULIC WRENCH KNOWLEDGE AND CREATED A WRENCH WITH A SHAPE WHICH IS UNIQUELY TORCUP. WITHIN THE BEAUTY OF THE SQ IS THE STRONGEST AND LONGEST TROUBLE-FREE OPERATING MECHANISM DESIGNED. THE PURPOSELY ENGINEERED THREE MOVING PARTS WITHIN THE SQ ARE THE RESULT OF 20 YEARS OF ON-SITE APPLICATION KNOWLEDGE. THE COMBINATION OF THE HIGHEST GRADE AEROSPACE ALLOYS AND FUTURISTIC MACHINING TECHNIQUES CREATE AN OUTPUT EFFICIENCY GREATER THAN ANY OTHER WRENCH ON THE MARKET. SIMPLY PUT...THERE IS NO COMPARISON TO THE SQ SERIES HYDRAULIC TORQUE WRENCH.



### THE POWER INSIDE

1. PATENTED MONO-BODY HOUSING
2. BALANCED DRIVE ROD
3. MULTI-TOOTH DRIVE SEGMENT
4. ANTI-BACK LASH MECHANISM
5. LASER ENGRAVED TORQUE CHART
6. MULTI-TOOTH RATCHET
7. ONE PIECE DRIVE PLATE
8. PUSH-THROUGH DRIVE
9. SINGLE SEAL PISTON
10. DIRECT HOUSING REACTION
11. STEEL REACTION BOOT
12. LONG LENGTH REACTION ARM
13. REACTION ARM THUMB RELEASE BUTTON
14. QUICK CONNECT NO-DRIP COUPLERS
15. 180° X 360° SINGLE SWIVEL MOVEMENT

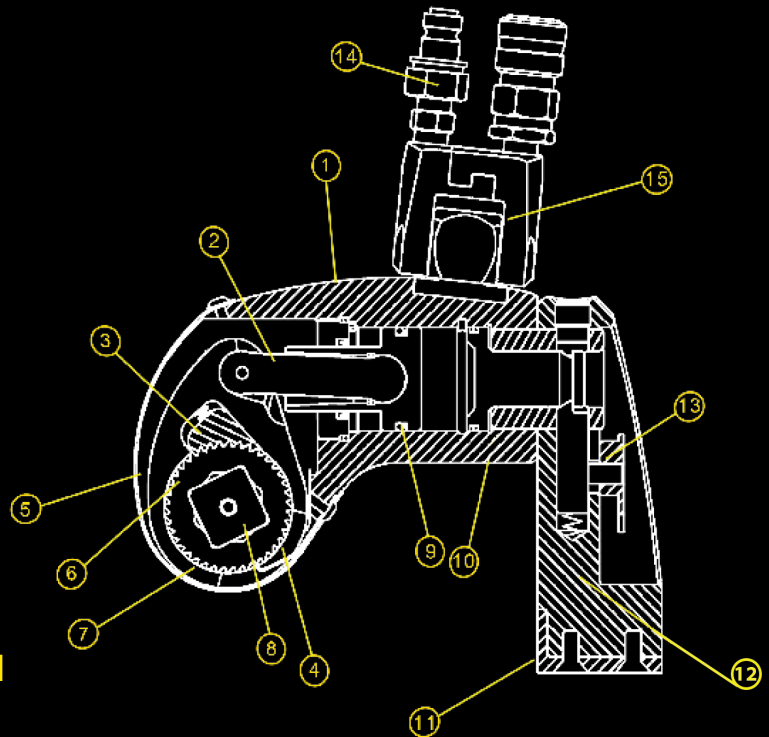



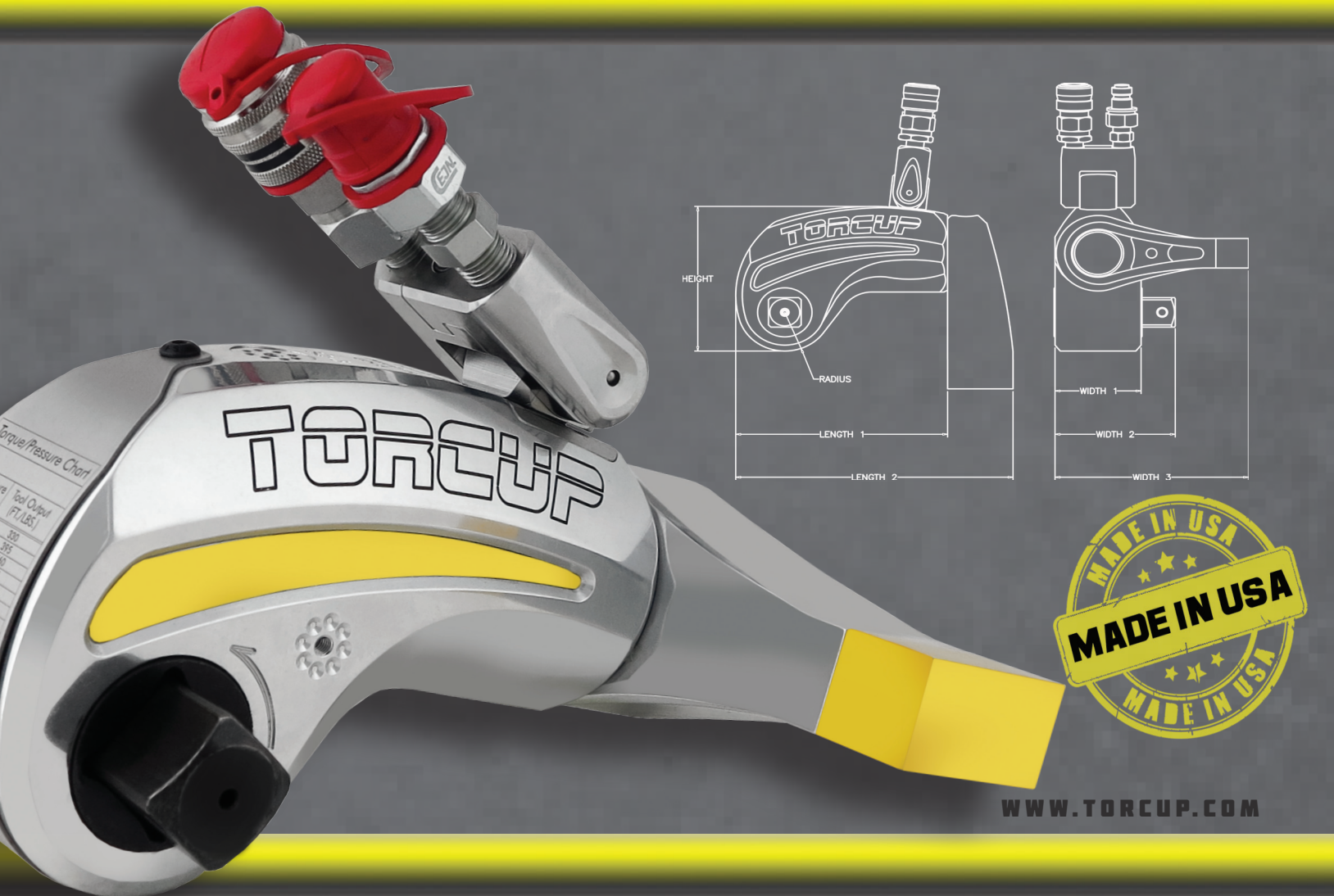

Torque/Pressure Chart  
 Tool Output (FT.LBS.)  
 330  
 395  
 460

WWW.TORCUP.COM

**POWER ENGINEERED**

MODEL NUMBER	SQ-1	SQ-3	SQ-5	SQ-10
SQUARE DRIVE	3/4"	1"	1 1/2"	1 1/2"
MIN. TORQUE (lbf-ft)*	156	379	507	956
MAX. TORQUE (lbf-ft)*	1414	3515	5523	10619
MIN. TORQUE (nm)*	212	515	690	1300
MAX. TORQUE (nm)*	1923	4780	7511	14443
OUTPUT ACCURACY	+/-3%	+/-3%	+/-3%	+/-3%
REPEATABILITY	100%	100%	100%	100%
DUTY CYCLE	100%	100%	100%	100%
TOOL WEIGHT (lbs)	5.5	11.0	18.5	32.0
TOOL WEIGHT (kgs)	2.5	5.0	8.4	14.5
HEIGHT (in)	3.76	4.91	6.05	7.34
HEIGHT (mm)	95.5	124.7	153.6	186.4
LENGTH 1 (in)	4.91	6.48	7.95	9.85
LENGTH 1 (mm)	124.7	164.5	201.9	250.1
LENGTH 2 (in)	6.47	8.48	10.70	12.85
LENGTH 2 (mm)	164.3	215.3	271.7	326.3
RADIUS (in)	0.99	1.31	1.57	2.13
RADIUS (mm)	25.1	33.2	39.8	54.1
WIDTH 1 (in)	2.0	2.63	3.13	3.95
WIDTH 1 (mm)	50.8	66.8	79.5	100.3
WIDTH 2 (in)	2.75	3.68	4.64	5.47
WIDTH 2 (mm)	69.8	93.5	117.8	138.9
WIDTH 3 (in)	4.61	5.92	7.0	8.74
WIDTH 3 (mm)	117.0	150.3	177.8	222.0

\*Reference values only. Consult calibration torque chart provided with tool.



**SQ** SERIES UNI-SWIVEL  
SQUARE DRIVE  
HYDRAULIC TORQUE WRENCH

**UNIQUE** - THE SHAPE THAT FITS  
**ENDURING** - 20 YEARS OF ENGINEERING  
**ADAPTABLE** - ACCESSORIES FOR EVERYWHERE

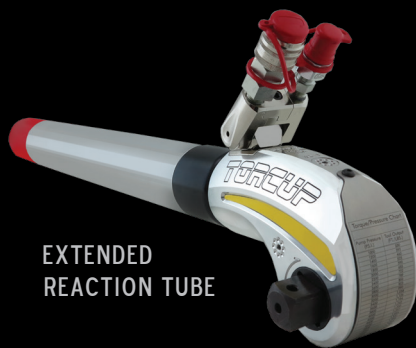

EXTENDED  
REACTION TUBE



DIRECT HEX  
ADAPTOR



END CAP  
PROTECTOR



TOOL  
HANDLE



NON PUSH THRU  
SQUARE DRIVE



WIDE BOOT  
REACTION ARM

**SQ SERIES**

Made In USA

Four Models From 156 lbf-ft to  
10,619 lbf-ft

Every Unit Calibrated In Our  
ISO17025 Laboratory

Manufactured With AQ  
Certified Alloys

Only Three Moving Parts

Genuine Torcup Design



**Worldwide Headquarters**

1025 Conroy Place

Easton, PA 18040 USA

TOLL FREE: 1-888-TorcUP-1

TELEPHONE: 1-610-250-5800

FAX: 1-610-250-2700

[www.torcup.com](http://www.torcup.com)



CARRYING  
CASE

