

VT Series

OPERATION AND MAINTENANCE

MANUAL

BATTERY-POWERED TORQUE WRENCHES

MODELS VT-500, VT-1000, VT-1000-1, VT-2000, VT-3000, AND VT-6000

VOLTA



TORCUPTM

1025 Conroy Place, Easton, PA. 18040 U.S.A.

Phone: 1 610-250-5800

Fax: 1 610-250-2700

Toll Free: 888-TORCUP1

Email: SALES@TORCUP.COM

Website: WWW.TORCUP.COM



Operational and Maintenance Manual for TorcUP
VT-500, VT-1000-1, VT-1000, VT-2000, VT-3000 &
VT-6000

Battery-Powered Torque Wrenches
Version 6: 2024 March

NOTICE

Series VT-500, VT-1000-1, VT-1000, VT-2000, VT-3000 and VT-6000 Battery-Powered Torque Wrenches are designed for installing and removing threaded fasteners requiring precise high torque during bolt makeup and maximum torque during bolt breakout.

TorcUP Inc. is not responsible for customer modification of tools or for applications on which TorcUP Inc. was not consulted.

WARNING

**IMPORTANT SAFETY INFORMATION ENCLOSED.
READ THIS MANUAL BEFORE OPERATING TOOL.
IT IS THE RESPONSIBILITY OF THE EMPLOYER TO PLACE THE INFORMATION IN THIS
MANUAL INTO THE HANDS OF THE OPERATOR.
FAILURE TO OBSERVE THE FOLLOWING WARNINGS COULD RESULT IN INJURY.**

**The Volta tools contain alloy components which may
cause a hazard in certain explosive environments.**

General Description of TorcUP VOLTA Series Battery-Powered Torque Wrenches

The VOLTA Series Battery-Powered Torque Wrench provides torque settings of up to 6,000 lbf-ft in clockwise rotation, and its free joint execution allows for random positioning of the tool.

The use of other than genuine TorcUP replacement parts may result in safety hazards, decreased tool performance, increased maintenance, and may invalidate all warranties. Repairs should be made only by authorized personnel. Consult your nearest TorcUP Authorized Service Center.

Refer All Communications to the Nearest TorcUP Office or Distributor.

For Technical Support & Information Contact:

TorcUP Inc.

1025 Conroy Place, Easton, PA 18040 USA

Phone: +1 610-250-5800 Fax: +1 610-250-2700

email: sales@torcup.com

WARNING

FAILURE TO OBSERVE THE FOLLOWING WARNINGS COULD RESULT IN INJURY

Keep body stance balanced and firm. Do not overreach when operating this tool.



Always wear eye protection when operating or performing maintenance on this tool.



Always wear ear protection when operating this tool.



The Reaction Arm must be positioned against a positive stop. Do not use the arm as a dead handle. Take precautions to make certain the operator's hand cannot be pinched between the arm and a solid object.



USING THE TOOL

- Keep hands, loose clothing and long hair away from the reaction arm and working area during operation.
- This tool will exert a strong reaction force. Use proper mechanical support and correct reaction arm positioning to control these forces. Do not position the reaction arm so that it tilts the tool off the axis of the bolt, and never use the air inlet as a reaction stop.
- Use only accessories recommended by TorcUP.
- Use only impact sockets and accessories rated for appropriate torque output. Do not use hand (chrome) sockets or accessories.
- Use only sockets and accessories that correctly fit the bolt or nut and function without tilting the tool off the axis of the bolt.
- This tool is not insulated against electric shock.
- This equipment must not be operated or serviced unless the operator reads the operating instructions and fully understands the purpose, consequences and procedures of each step.

Depending on the working environment, your local health and safety regulations may require you wear protective gear (i.e. safety shoes, hard hat, gloves, coveralls, etc.). In case external forces are exerted on the equipment, non-compliance with these regulations may result in injury. **EAR PROTECTION MUST BE WORN WHEN OPERATING THIS TOOL.**

SAFETY INFORMATION

OPERATIONAL SAFETY

1. Inspect, maintain, operate and install the tool in accordance with all applicable standards and regulations (local, state, county, federal, etc.)
2. Do not remove any labels. Replace any damaged labels immediately.
3. Do not lubricate tools with flammable or volatile liquids such as kerosene, diesel or jet fuel. Only use TorcUP recommended lubricants.
4. Only use proper cleaning solvents to clean parts. Use only cleaning solvents which meet current safety and health standards. Use cleaning solvents in a well ventilated area.
5. Keep work area clean, uncluttered, ventilated and illuminated.

PERSONAL SAFETY

1. When wearing gloves, always be sure that the gloves will not prevent the throttle mechanism from being released.
2. Always wear eye protection when operating or performing maintenance on this tool.
3. Always wear hearing protection when operating this tool.
4. Always use Personal Protective Equipment appropriate to the tool used and the material being worked on. This may include dust mask or other breathing apparatus, safety glasses, ear plugs, gloves, apron, safety shoes, hard hat and other equipment.
5. Avoid breathing in any exhaust from tool use.
 - a. Some dust may also be created by working in close proximity to the following chemicals:
 - i. Lead from lead-based paints
 - ii. Crystalline silica from bricks and cement and other masonry products
 - iii. Arsenic and chromium from chemically treated lumber

Your risk from these exposures varies depending on how often you do this type of work.

To reduce your exposure to these chemicals: work in a well ventilated area, and work with approved safety equipment, such as dust masks that are specially designed to filter out microscopic particles.

6. Keep others at a safe distance from your work area or ensure they use appropriate personal protective equipment.
7. Be aware of buried, hidden or other hazards in your work environment. Do not contact or damage cords conduits, pipes, or hoses that may contain electrical wires, explosive gases or harmful liquids.
8. Keep hands, loose clothing, long hair and jewelry away from the working end of the tool.
9. Power tools can vibrate in use. Vibration, repetitive motions or uncomfortable positions may be harmful to your hands and arms. Stop using any tool if discomfort, tingling feeling or pain occurs. Seek medical advice before resuming.
10. Keep your body stance balanced and firm. Do no overreach when operating this tool. Anticipate and be alert for sudden changes in motion, reaction torques, or forces during start up and operation.
- 11. DO NO USE THE TOOL WHEN TIRED OR WHEN UNDER THE INFLUENCE OF MEDICATION, DRUGS OR ALCOHOL.**
12. Never use a damaged or malfunctioning tool or accessory.
13. Do not modify the tools, safety devices or accessories.
14. Do not use this tool for purposes other than those recommended.

PLACING THE TOOL IN SERVICE

PLACING THE TOOL IN SERVICE

1. Ensure the reaction arm is properly attached and secured to the splined section of the torque tool.
2. Select your desired square drive size and bolt/nut AF size impact socket or hex-drive socket for use.
3. Secure impact socket onto the tool square drive with a safety pin and secure a safety o-ring on the socket.
4. See illustration below for details:

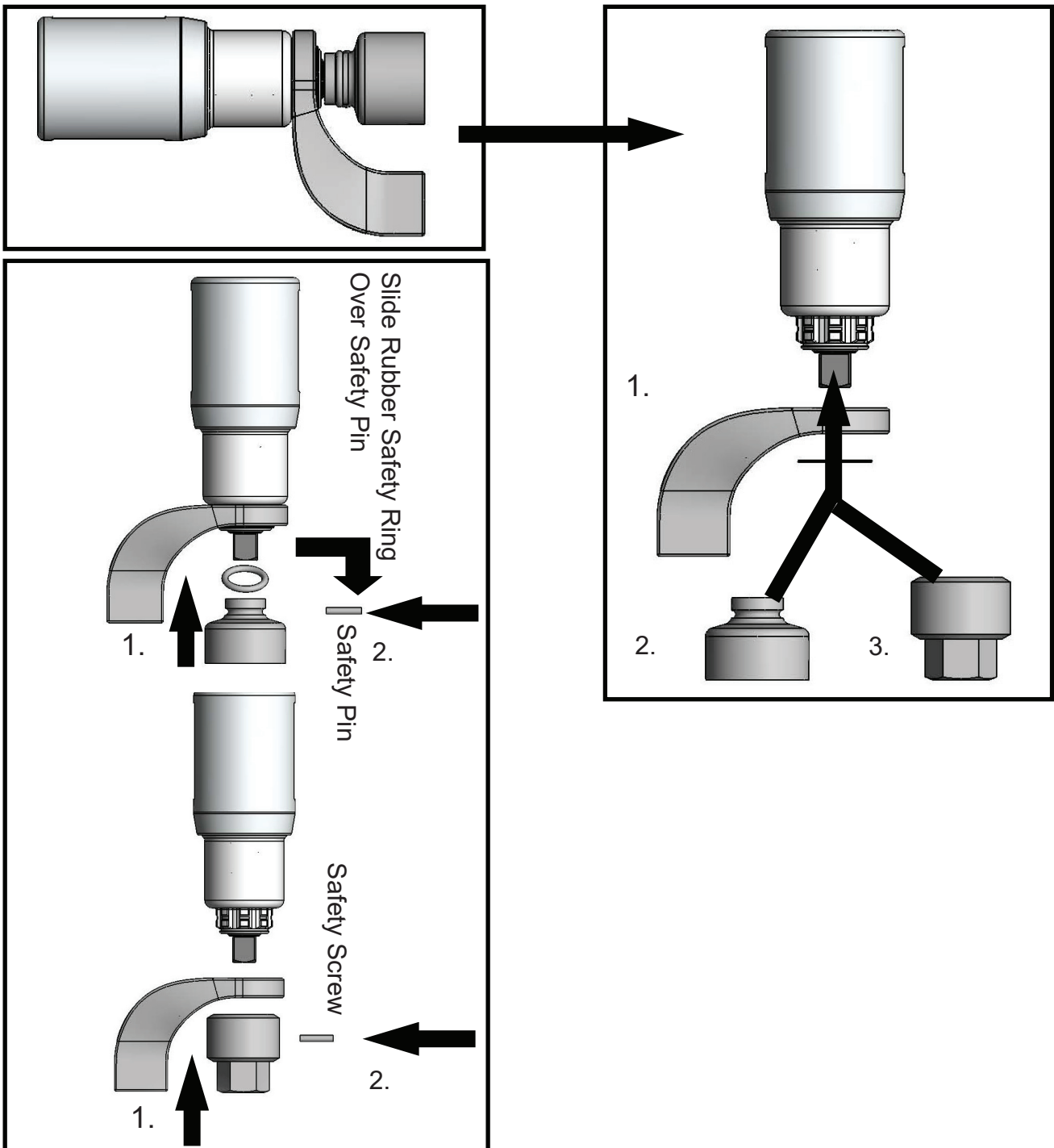

OPERATING PROCEDURES

SETTING THE TORQUE

1. Momentarily press Volta trigger to activate LCD display (the board will remain illuminated for approximately 30 seconds after the trigger is released).
2. Use the two arrows to set desired torque. Pressing the arrow pointed upward will raise the torque and pressing the arrow pointed downward will lower the torque (pressing and holding a button will cycle through the torque settings).
3. Simultaneously pressing the up and down arrows will switch the display torque between lbf-ft and Nm (NOTE: TRANSITIONING UNITS AUTOMATICALLY RESETS THE TORQUE TO THE LOWEST POSSIBLE VALUE).
4. After the LCD times out, pull the trigger to reactivate it, the torque setting will remain set until changed.

TORQUE THROUGH THE LIFE OF THE BATTERY

If the tool is used continuously/rapidly to the point that the tool feels hot to the touch, the tool accuracy can diminish and cause a slight increase in torque. Once the tool cools down, the accuracy should return to normal.

The battery is recommended to be changed before the charge gets to 25% battery life, although the torque should be consistent until the last few fastenings before the battery dies.

NOTE: This tool is designed to be operated with right-hand thread fasteners. There is a 15% reverse bias to assist with breakout. If this tool is to be used with left-hand thread fasteners consult TorcUP.

OPERATING PROCEDURES

NOTICE

After extended use of the VOLTA Series Torque Wrench, in the case of degrading performance or other apparent damage, immediately send your VOLTA Series Torque Wrench to TorcUP, Inc or contact your Local Representative or Distributor. The unit must be properly packaged for shipping.

TIGHTENING AND LOOSENING OF BOLTS OR NUTS

WARNING

TIGHTENING AND LOOSENING OF BOLTS OR NUTS

- Beware of non-fixed, freely rotating reaction arms or of rotating impact sockets.
- Loose clothes, long hair, cables, etc. are always to be kept away from the danger/rotation area. When the machine is put into operation, it is mandatory to wear ear protection, safety shoes and safety goggles.
- Maintain a safe distance from all reaction points.
- Always place the impact socket or hex driver snugly onto the screw or nut/bolt. Faulty screw or nut/bolt connections may result in exceeding the mechanical stress limit of the material, causing it to break. Parts that splinter off may cause bruises or even life-threatening injuries.

When tightening and loosening fasteners, always hold/position the VOLTA Series Torque Wrench in line with the fastener axis to avoid damage to the application. See Figure 1 on the following page.

TIGHTENING AND LOOSENING OF BOLTS OR NUTS

Fig. 1

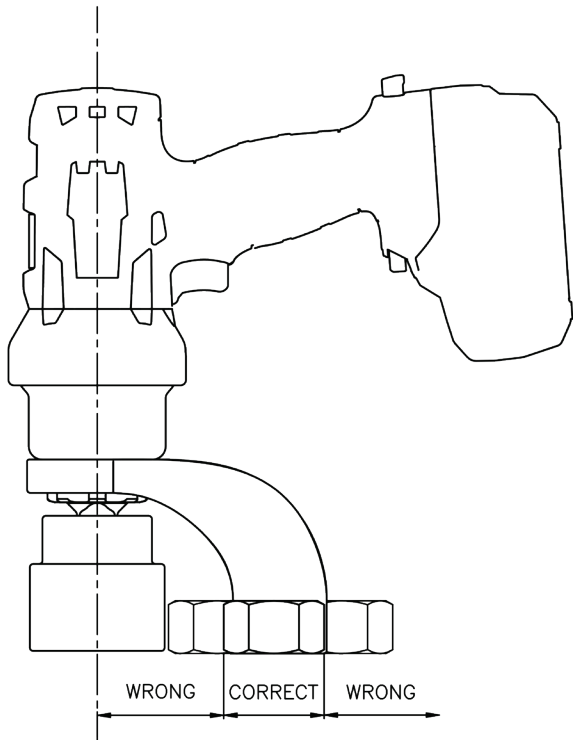

1. Place your VOLTA Series Torque Wrench completely over and on the fastener to be tightened or loosened.
2. Ensure the reaction area / movement is taken up by the Reaction Arm. Also, ensure the reaction is stable and will support counter torque.
3. Hold the VOLTA Series Torque Wrench perpendicular to the fastener axis for the complete duration of the rotation process for tightening or loosening.
4. Ensure the direction switch is set to **tighten**. Then, press the trigger on the pistol grip to tighten the fastener. The tool will rotate until the fastener becomes torqued, and the VOLTA Series Torque Wrench will then stop/beep.
5. For loosening a fastener, place the direction switch in **reverse**. Then, press the trigger on the pistol grip to loosen the fastener.

The unit will continue to rotate until the fastener is removed OR once the fastener is loose it can be removed by hand and you can move on to the next fastener.

6. Continue the process for tightening or loosening for each fastener you require.
7. If torque requirements necessitate the use of torque increments, set the VOLTA Series Torque Wrench to your first torque requirement. Tighten fastener as per your required tightening bolt sequence. Then, reset for the next setting(s).
8. Your personnel can be trained by your TorcUP Representative or Distributor on use of this product if so desired.

CHANGING ACCESSORIES

1. Remove the VOLTA Series Torque Wrench from the application.
2. Disconnect the battery to the VOLTA Series Torque Wrench.
3. Remove and change the socket or accessory adaptor for the next project. Ensure the socket or accessory is properly secured to the square drive with a locking pin and safety securing o-ring.

BATTERY SAFETY INSTRUCTIONS

NOTICE

Note: Prior to use, please see pages 17-21 of this user manual to review the battery product safety data sheet.

1. Do not expose power tools to rain or wet conditions. Water entering a power tool will increase the risk of electric shock and damage the tool.
2. Disconnect the battery pack from the power tool before changing accessories or storing power tools. Such preventive safety measures reduce the risk of starting the power tool accidentally.
3. Store idle power tools out of the reach of children and do not allow persons unfamiliar with the power tool or these instructions to operate the power tool. Power tools are dangerous in the hands of untrained users.
4. Maintain power tools. Check for misalignment or binding of moving parts, breakage of parts and any other condition that may affect the power tool's operation. If damaged, have the power tool repaired before use. Many accidents are caused by poorly maintained power tools.
5. Use the power tool, accessories and tool bits etc. in accordance with these instructions, taking into account the working conditions and the work to be performed. Use of the power tool for operations different from those intended could result in a hazardous situation.

BATTERY USE AND CARE

1. Recharge only with the charger specified by the manufacturer. A charger that is suitable for one type of battery pack may create a risk of fire when used with another battery pack.
2. Use power tools only with specifically designated battery packs. Use of any other battery packs may create a risk of injury and fire.
3. When battery pack is not in use, keep it away from other metal objects, like paper clips, coins, keys, nails, screws or other small metal objects, that can make a connection from one terminal to another. Shorting the battery terminals together may cause burns or a fire.
4. Under abusive conditions, liquid may be ejected from the battery; avoid contact. If contact accidentally occurs, flush with water. If liquid contacts eyes, additionally seek medical help. Liquid ejected from the battery may cause irritation or burns.
5. Protect battery packs from water and moisture.
6. Do not expose battery packs to open flame.

BATTERY TROUBLESHOOTING

If the VOLTA Series Torque Wrench switches off automatically, the electronics have activated automatic protection mode. A warning signal sounds (continuous beeping). The beeping stops after a maximum of 30 seconds or when the trigger is released. In spite of this protective function, overloading is still possible with certain applications and can result in damage to the tool.

Causes and Remedies:

- 1. Battery almost empty:** The electronics protect the battery pack against damage through total discharge). If one LED is flashing, the battery pack is almost depleted. If necessary, press the button and check the LEDs to see the charge level. If the battery pack is almost depleted, it must be recharged.
- 2. Long continuous overloading of the machine:** This will activate the temperature cut-out. Leave the tool or battery pack to cool. **Note:** If the battery pack feels very warm, the pack will cool more quickly in an "AIR COOLED" charger. **Note:** The tool will cool more quickly if you operate it at idling speed.
- 3. Safety Shutdown:** The tool was SWITCHED OFF automatically. If the slew rate of the current is too high (for example, if the tool suddenly seizes or kickback occurs), the tool switches off. Switch off the tool at the trigger. Switch it on again and continue to work as normal. Try to prevent the tool from seizing.

Note: The LED lamp switches off automatically after a specific time. To activate the electronic functions, press the trigger.

TECHNICAL SPECIFICATIONS

MODEL NUMBER	VOLTA 500	VOLTA 1000-1	VOLTA 1000	VOLTA 2000	VOLTA 3000	VOLTA 6000
SQUARE DRIVE	3/4"	3/4"	1"	1"	1"	1.5"
MIN. TORQUE (lbf-ft)	120	240	240	500	750	1200
MAX. TORQUE (lbf-ft)	500	1000	1000	2000	3000	6000
MIN. TORQUE (Nm)	160	330	330	680	1020	1630
MAX. TORQUE (Nm)	680	1360	1360	2710	4070	8130
HEIGHT A (w/ battery) (in)	10.57	10.54	10.54	10.54	10.76	11.38
HEIGHT A (w/ battery) (mm)	268.48	267.67	267.67	267.67	273.18	289.05
LENGTH B (in)	7.65	9.08	9.28	9.72	12.49	13.17
LENGTH B (mm)	194.28	230.73	235.59	246.84	317.14	334.42
DIAMETER C (in)	3.32	2.85	2.85	3.10	3.75	5.00
DIAMETER C (mm)	84.25	72.39	72.39	78.64	95.25	127
WEIGHT (w/o reaction arm & battery) (lbs)	6.6	9.15	9.6	11.2	17.7	33.5
WEIGHT (w/o reaction arm & battery) (kg)	2.99	4.15	4.35	5.08	8.03	15.19
WEIGHT (w/ reaction arm & battery) (lbs)	10.85	13.4	14.65	16.25	22.75	43.3
WEIGHT (w/ reaction arm & battery) (kg)	4.92	6.08	6.64	7.37	10.32	19.64
RPM at Min. Torque	12.25	4.5	4.5	2.9	1.5	0.9
RPM at Max Torque	17.5	6.75	6.75	4.25	2	1.2

Charger Requirements: 110 - 120 V (50-60 Hz) and 230 - 240 V (50-60 Hz)

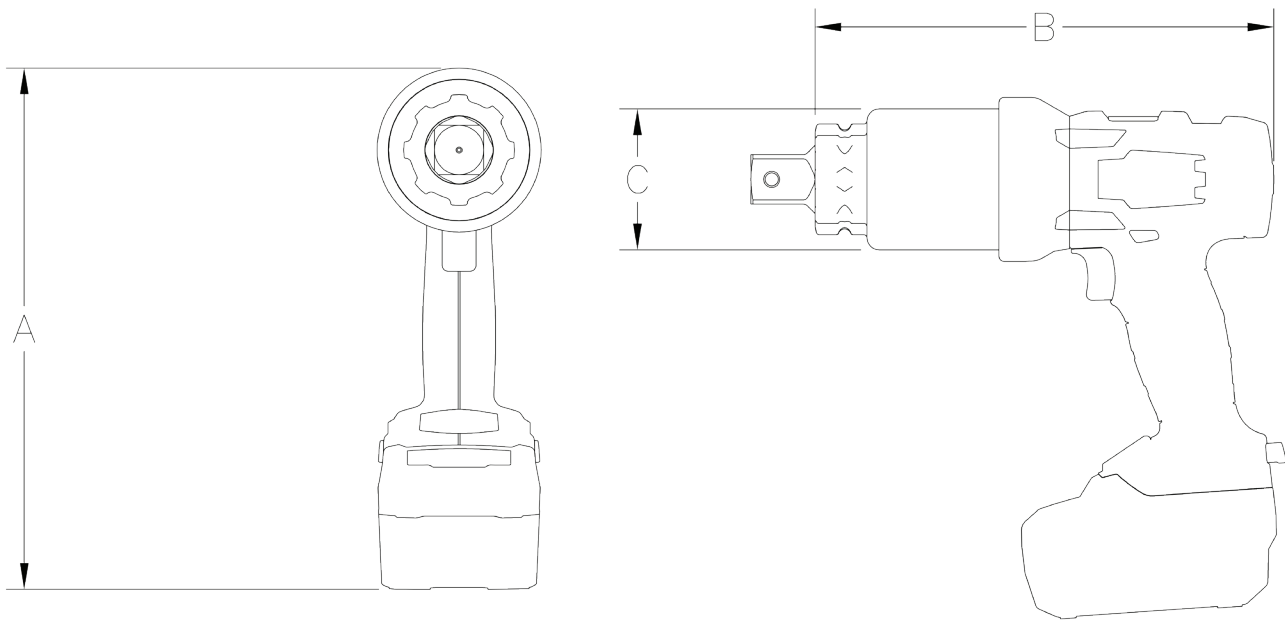

Volta Series Handle (Electrical)

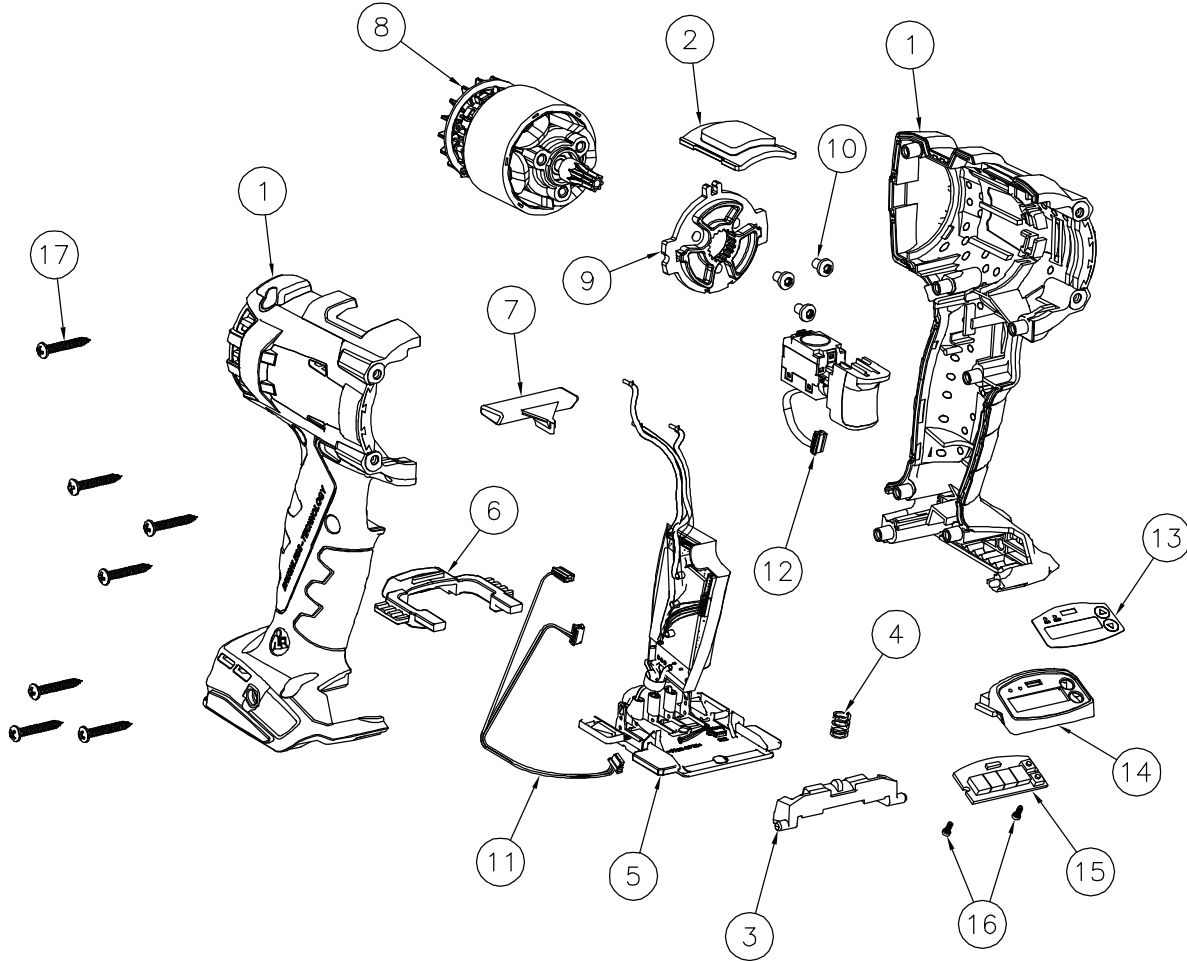

Part Numbers for Ordering

ITEM	NAME	PART #	QTY.
1	Black Handle Housing (Set)	VT-DH-HOUSING	1
2	Transmission Plate	VT-ADPTR-7	1
3	Battery Locking Piece	VT-DH-LOCKPIECE	1
4	Battery Lock Pressure Spring	VT-DH-LOCKSPRING	1
5	Electric Controller (x.xs backoff)	VT-DH-ELECT(x.xs)*	1
6	Battery Lock Slide	VT-DH-LOCKSLIDE	1
7	Handle R/L Slide Switch	VT-DH-R/LSLIDE	1
8	18v Motor w/ Pinion	VT-DH-MOTORW/PINION	1
9	Gear/Motor Flange	VT-DH-GEARFLANGE	1
10	Motor Flange Screw	VT-DH-GEARFLANGE-SCREW	3
11	Controller Cable Assembly	VT-CNTRL-WH01	1
12	Trigger Switch	VT-DH-TRIGGER	1
13	Display Cover Label	LBL-VT-DISPLAY	1
14	Display Cover	VT-CNTRL-COVER	1
15	Controller PCB	VT-CNTRL-PCB	1
16	Controller PCB Screw	VT-CNTRL-SCREW	2
17	Housing Screw	VT-DH-SCREW	7

*Electric controller part numbers:

VT-500, VT-1000, VT-1000-1	VT-DH-ELECT(0.3s)
VT-2000	VT-DH-ELECT(0.6s)
VT-1000E6, VT-3000, VT-6000	VT-DH-ELECT(1.0s)

Volta Series Handle

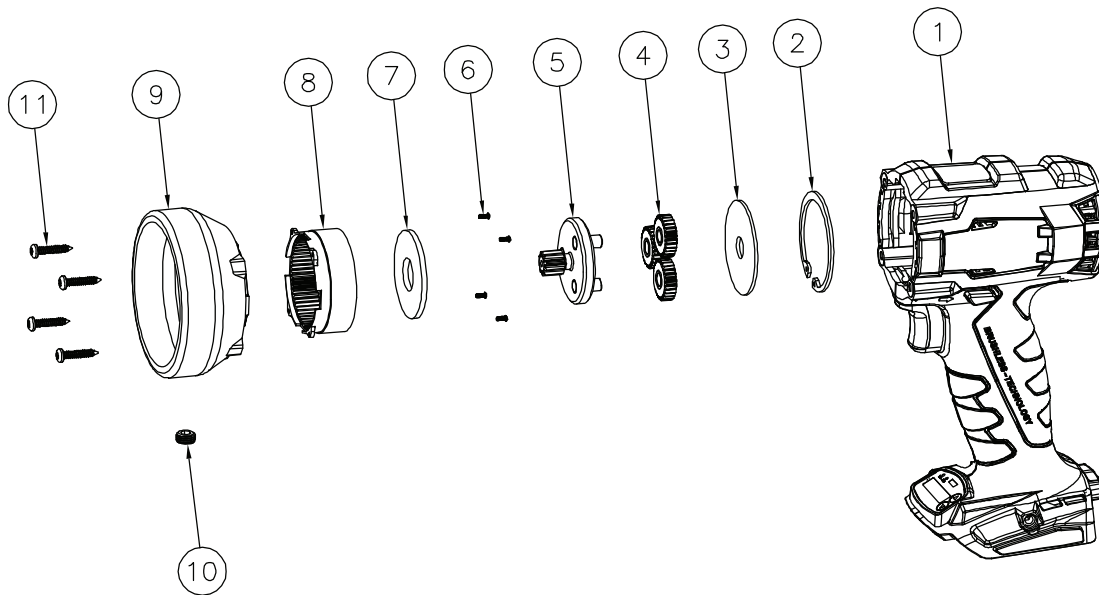

Part Numbers for Ordering

ITEM	NAME	PART #	QTY.
1	Handle	VT-(xx)-DH	1
2	Retaining Ring	VT-ADPTR-9	1
3	Retaining Plate	VT-ADPTR-42	1
4	Planetary Gears	VT-ADPTR-52	3
5	Gear Carrier Assembly (VT-500)	VT-ADPTR-22-RPGB-H	1
5	Gear Carrier Assembly (All Other Models)	VT-ADPTR-22	1
6	Ring Gear Screws	VT-ADPTR-8	4
7	Nylon Washer	VT-ADPRT-11	1
8	Ring Gear	VT-ADPTR-32	1
9	Gearbox Adapter (VT-500)	VT-ADPTR-6-RPGB	1
9	Gearbox Adapter (All Other Models)	VT-ADPTR-6	1
10	Bearing Ball Retainer	VT-ADPTR-13	1
11	Housing Screws	VT-DH-SCREW	4

VT-500 Series Wrench

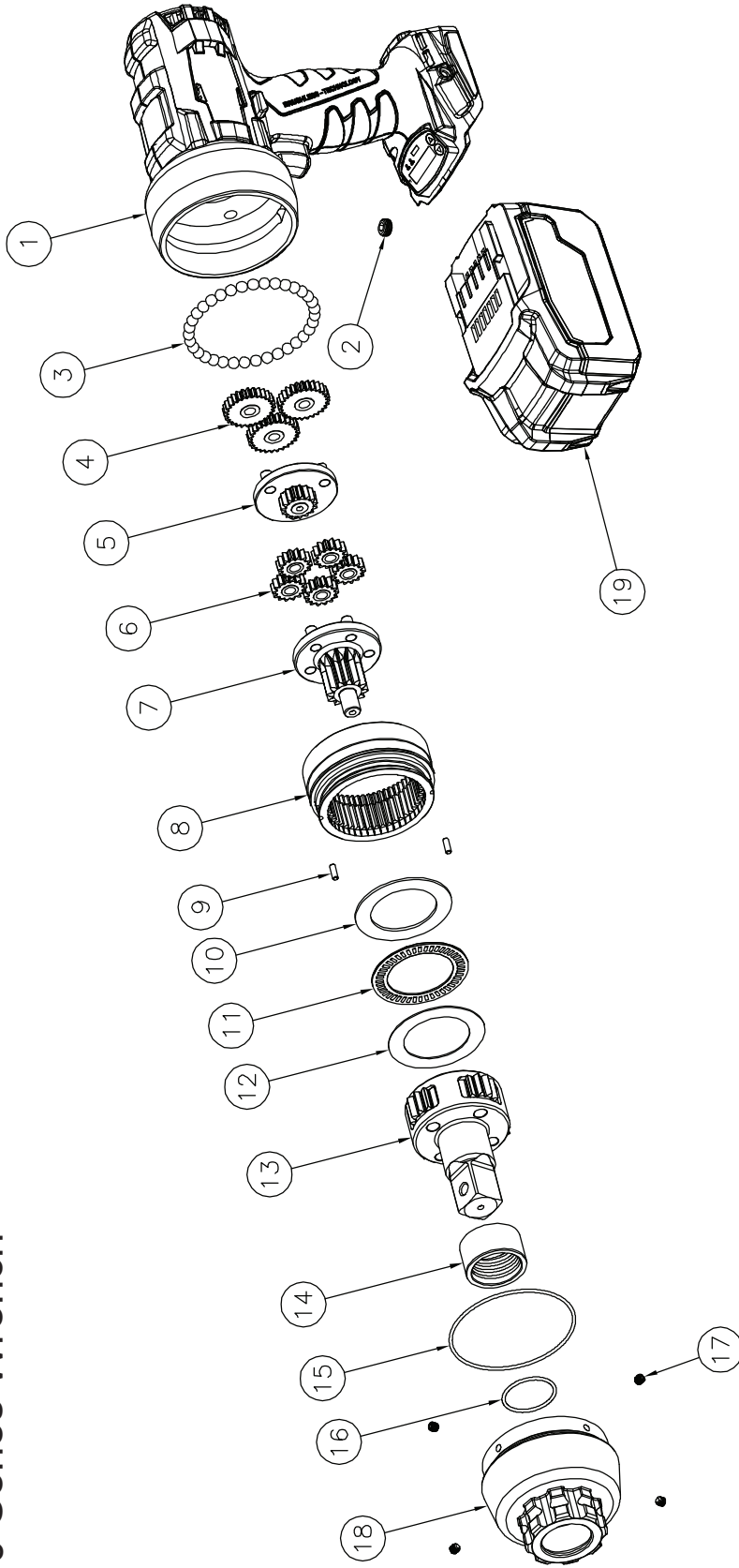

Part Numbers for Ordering

ITEM	NAME	PART #	QTY.
1	Volta Handle	VT-05-DH-ASSY	1
2	Ball Retainer	VT-ADPTR-13	1
3	Steel Ball	RP-CM-BB	35
4	1st Stage Spur Gear	RP3-05-ST1-G	3
5	1st Stage Gear Carrier	RP3-05-ST1	1
6	2nd Stage Spur Gear	RP3-05-ST2-G	5
7	2nd Stage Gear Carrier	RP3-05-ST2	1
8	High Speed Annulus	RP3-05-HSA	1
9	High Speed Annulus Dowel	RP3-05-DOWEL	2
10	Thrust Washer B	RP3-05-TRB	1

ITEM	NAME	PART #	QTY.
11	Needle Roller Thrust Bearing	RP3-05-NRB	1
12	Thrust Washer A	RP3-05-TRA	1
13	Drive Stage Assembly	RP3-05-DSTA	1
14	Main Bearing	RP3-05-MB	1
15	Main Annulus O-Ring	RP-CM-OR-MA	1
16	Drive Annulus O-Ring	RP3-05-OR-DA	1
17	Drive Annulus Set Screw	RP3-05-SS-DA	4
18	Drive Annulus	RP3-05-DA	1
19	Lithium Ion Battery	VT-BATT-18V-#AH	1

VT-1000 Series Wrench with 3/4" Drive

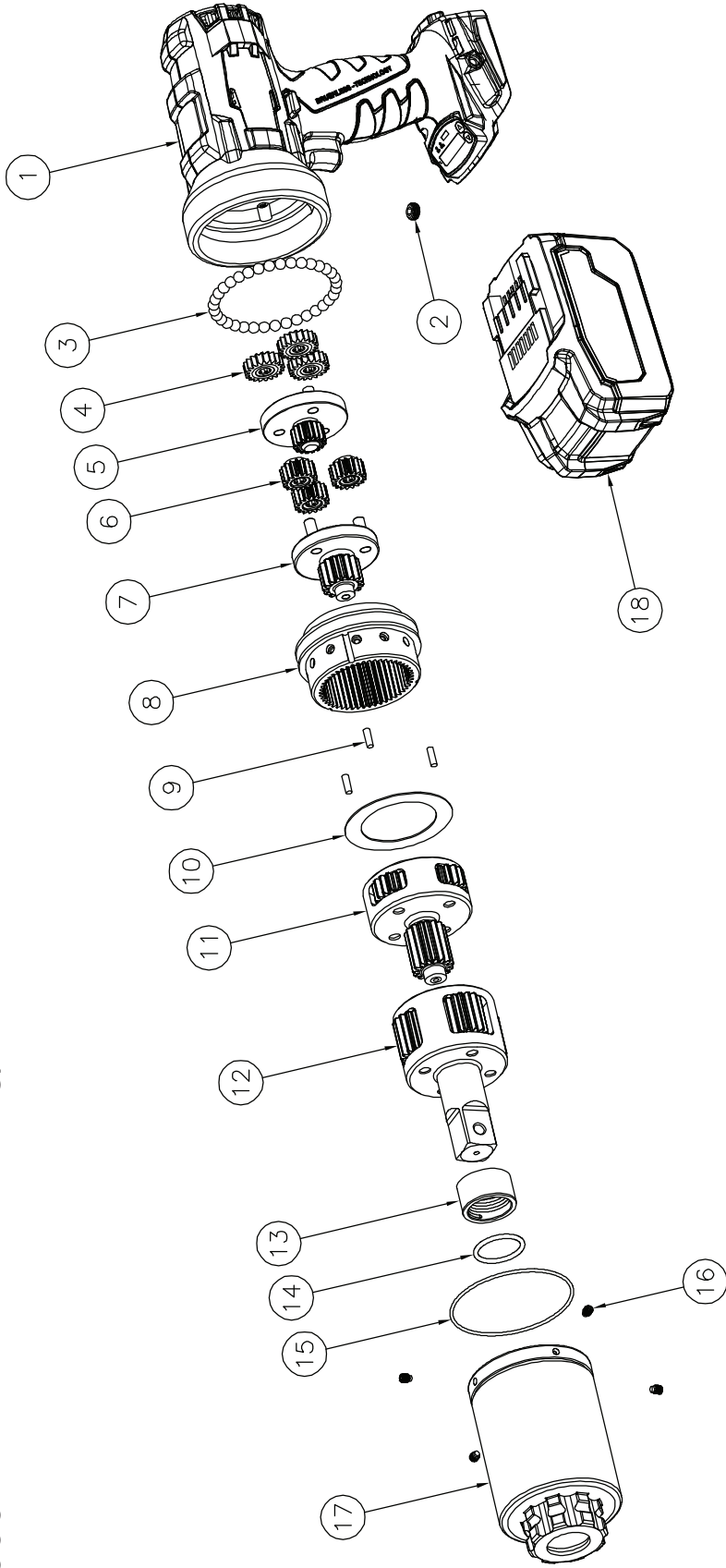

Part Numbers for Ordering

ITEM	NAME	PART #	QTY.
1	Volta Handle	VT-10-DH-ASSY	1
2	Ball Retainer	VT-ADPTR-13	1
3	Steel Ball	RP-CM-BB	35
4	1st Stage Spur Gear	RP-10-ST1-G	3
5	1st Stage Gear Carrier	RP-10-ST1	1
6	2nd Stage Spur Gear	RP-10-ST2-G	3
7	2nd Stage Gear Carrier	RP-10-ST2	1
8	High Speed Annulus	RP-10.30-HSA	1
9	High Speed Annulus Dowel	RP3-05-DOWEL	3

ITEM	NAME	PART #	QTY.
10	Thrust Washer	RP-10-TW	1
11	3rd Stage Assembly	RP-10-ST3A	1
12	Drive Stage Assembly	RP-10-DSTA	1
13	Main Bearing	RP-10-MB	1
14	Drive Annulus O-Ring	RP-10-OR-DA	1
15	Main Annulus O-Ring	RP-CM-OR-MA	1
16	Drive Annulus Set Screw	RP-CM-SS-DA	4
17	Drive Annulus	RP-10-DA	1
18	Lithium Ion Battery	VT-BATT-18V-#.AH	1

VT-1000 Series Wrench with 1" Drive

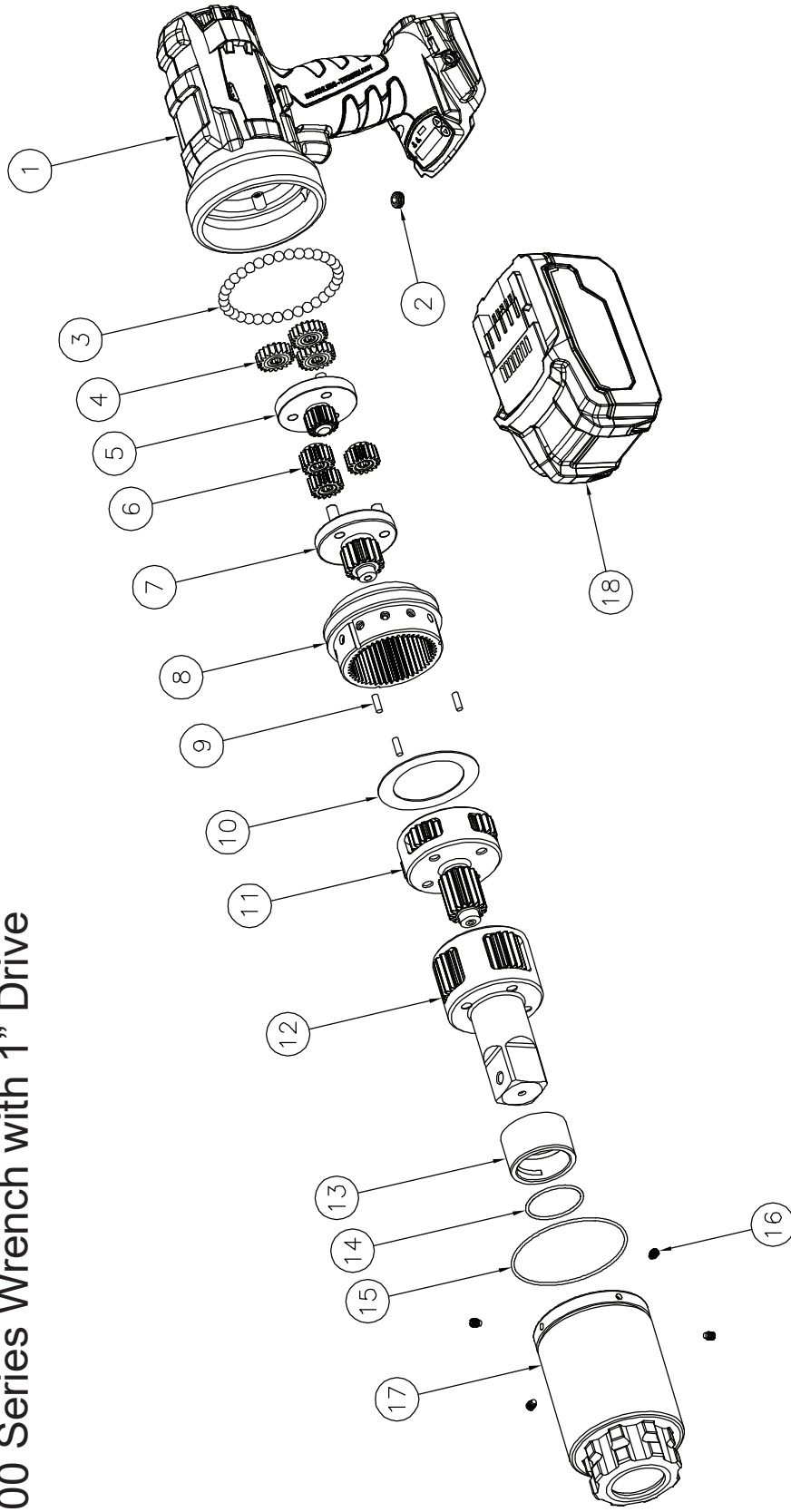

Part Numbers for Ordering

ITEM	NAME	PART #	QTY.
1	Volta Handle	VT-10-DH-ASSY	1
2	Ball Retainer	VT-ADPTR-13	1
3	Steel Ball	RP-CM-BB	35
4	1st Stage Spur Gear	RP-10-ST1-G	3
5	1st Stage Gear Carrier	RP-10-ST1	1
6	2nd Stage Spur Gear	RP-10-ST2-G	3
7	2nd Stage Gear Carrier	RP-10-ST2	1
8	High Speed Annulus	RP-10.30-HSA	1
9	High Speed Annulus Dowel	RP3-05-DOWEL	3

ITEM	NAME	PART #	QTY.
10	Thrust Washer	RP-10-TW	1
11	3rd Stage Assembly	RP-10-ST3A	1
12	Drive Stage Assembly	RP-10-DSTA-1	1
13	Main Bearing	RP-10-MB-1	1
14	Drive Annulus O-Ring	RP-10-OR-DA-1	1
15	Main Annulus O-Ring	RP-CM-OR-MA	1
16	Drive Annulus Set Screw	RP-CM-SS-DA	4
17	Drive Annulus	RP-10-DA-1	1
18	Lithium Ion Battery	VT-BATT-18V-#.AH	1

VT-2000 Series Wrench

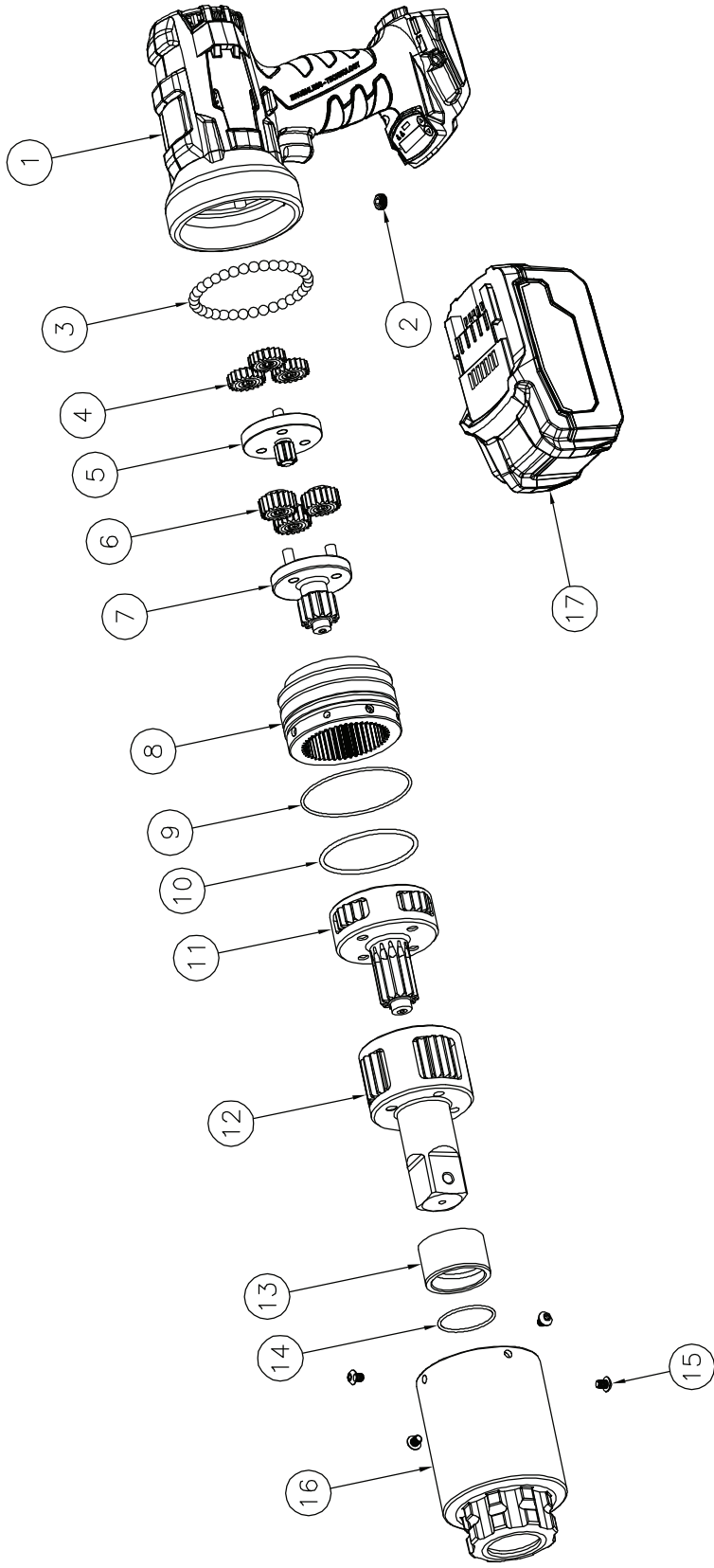

Part Numbers for Ordering

ITEM NAME	PART #	QTY.
1 Volta Handle	VT-20-DH-ASSY	1
2 Ball Retainer	VT-ADPTR-13	1
3 Steel Ball	RP-CM-BB	35
4 1st Stage Spur Gear	RP-20-ST1-G	3
5 1st Stage Gear Carrier	RP-20-ST1	1
6 2nd Stage Spur Gear	RP-20-ST2-G	3
7 2nd Stage Gear Carrier	RP-20-ST2	1
8 High Speed Annulus	RP-20.60-HSA	1
9 Main Annulus O-Ring (Small)	RP-CM-OR-MA	1

ITEM NAME	PART #	QTY.
10 Main Annulus O-Ring (Large)	RP-20.60-OR-MA	1
11 3rd Stage Assembly	RP-20-ST3A	1
12 Drive Stage Assembly	RP-20-DSTA	1
13 Main Bearing	RP-20-MB	1
14 Drive Annulus O-Ring	RP-20-OR-DA	1
15 Drive Annulus Set Screw	RP-20.60-SS-DA	4
16 Drive Annulus	RP-20-DA	1
17 Lithium Ion Battery	VT-BATT-18V-#.AH	1

VT-3000 Series Wrench

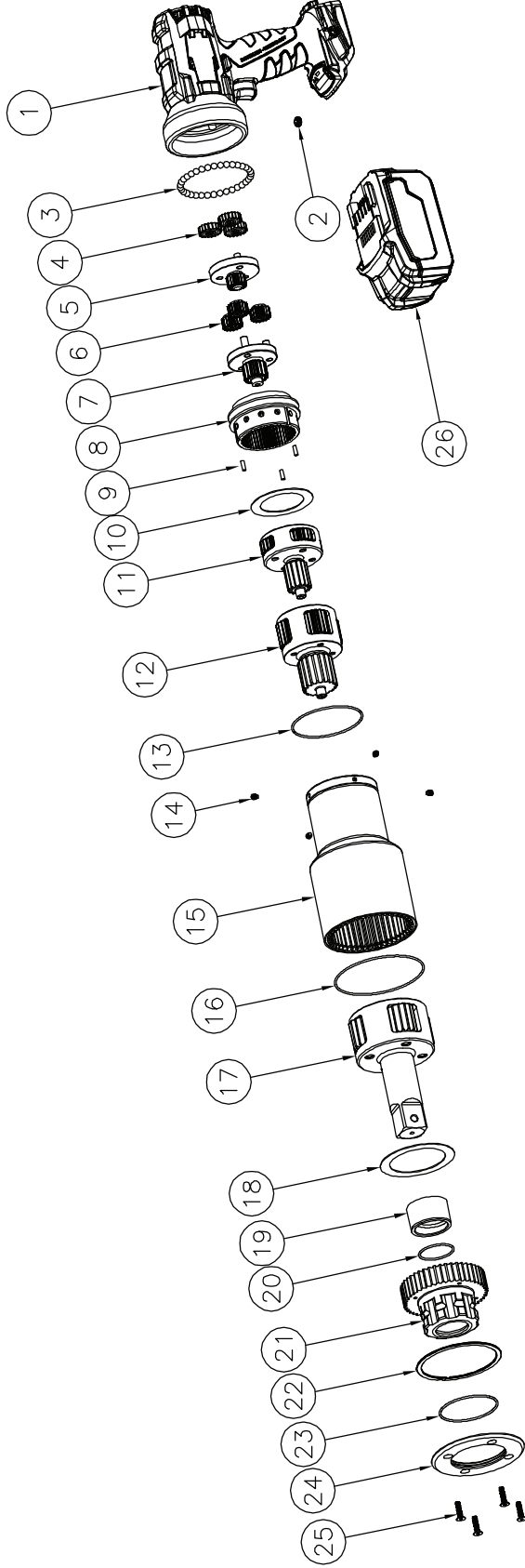

Part Numbers for Ordering

ITEM	NAME	PART #	QTY.	ITEM	NAME	PART #	QTY.
1	Volta Handle	VT-30-DH-ASSY	1	14	Drive Annulus Set Screw	RP-CM-SS-DA	4
2	Ball Retainer	VT-ADPTR-13	1	15	Drive Annulus	RP-30-DA	1
3	Steel Ball	RP-CM-BB	35	16	Drive Annulus O-Ring	RP-30-OR-DA	1
4	1st Stage Spur Gear	RP-30-ST1-G	3	17	Drive Stage Assembly	RP-30-DSTA	1
5	1st Stage Gear Carrier	RP-30-ST1	1	18	Drive Stage Thrust Washer	RP-30-DSTA-TW	1
6	2nd Stage Spur Gear	RP-30-ST2-G	3	19	Main Bearing	RP-30-IB	1
7	2nd Stage Gear Carrier	RP-30-ST2	1	20	Annulus Head O-Ring	RP-30-OR-AH	1
8	High Speed Annulus	RP-10.30-HSA	1	21	Annulus Head	RP-30-AH	1
9	High Speed Annulus Dowel	RP3-05-DOWEL	3	22	Retaining Ring	RP-30-RR	1
10	High Speed Thrust Washer	RP-30-HSA-TW	1	23	Annulus Cap O-Ring	RP-30-OR-AC	1
11	3rd Stage Assembly	RP-30-ST3A	1	24	Annulus Cap	RP-30-AC	1
12	4th Stage Assembly	RP-30-ST4A	1	25	Annulus Head Screw	RP-30-AH-SCREW	4
13	Main Annulus O-Ring	RP-CM-OR-MA	1	26	Lithium Ion Battery	VT-BATT-18V-#AH	1

VT-6000 Series Wrench

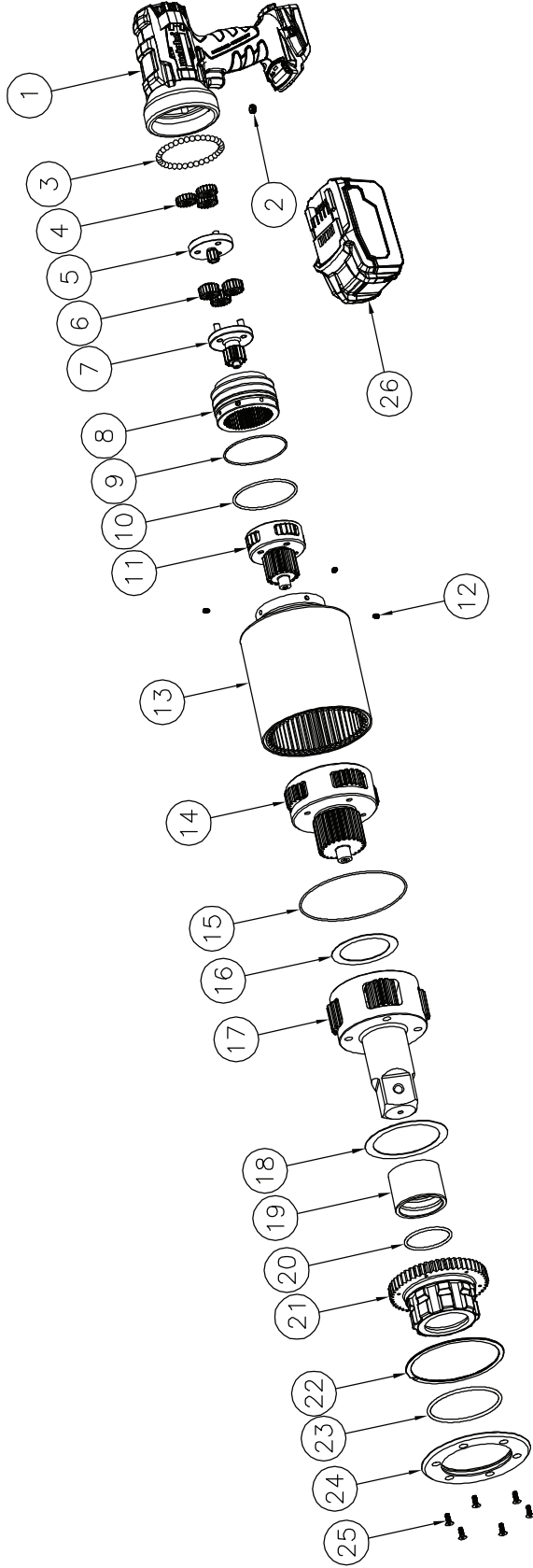

Part Numbers for Ordering

ITEM	NAME	PART #	QTY.	ITEM	NAME	PART #	QTY.
1	Volta Handle	VT-30-DH-ASSY	1	14	4th Stage Assembly	RP-60-ST4A	1
2	Ball Retainer	VT-ADPTR-13	1	15	Drive Annulus O-Ring	RP-60-OR-DA	1
3	Steel Ball	RP-CM-BB	35	16	4th Stage Thrust Washer	RP-60-ST4A-TW	1
4	1st Stage Spur Gear	RP-60-ST1-G	3	17	Drive Stage Assembly	RP-60-DSTA	1
5	1st Stage Gear Carrier	RP-60-ST1	1	18	Drive Stage Thrust Washer	RP-60-DSTA-TW	1
6	2nd Stage Spur Gear	RP-60-ST2-G	3	19	Main Bearing	RP-60-MB	1
7	2nd Stage Gear Carrier	RP-60-ST2	1	20	Annulus Head O-Ring	RP-60-OR-AH	1
8	High Speed Annulus	RP-20.60-HSA	1	21	Annulus Head	RP-60-AH	1
9	Main Annulus O-Ring (Small)	RP-CM-OR-MA	1	22	Retaining Ring	RP-60-RR	1
10	Main Annulus O-Ring (Large)	RP-20.60-OR-MA	1	23	Annulus Cap O-Ring	RP-60-OR-AC	1
11	3rd Stage Assembly	RP-60-ST3A	1	24	Annulus Cap	RP-60-AC	1
12	Drive Annulus Set Screw	RP-20.60-SS-DA	4	25	Annulus Head Screw	RP-60-AH-SCREW	4
13	Drive Annulus	RP-60-DA	1	26	Lithium Ion Battery	VT-BATT-18V-#.AH	1

MSDS

JET-LUBE, INC. MATERIAL SAFETY DATA SHEET

Product Name: MARINE MOLY™ Chemical Family: Petroleum based lubricating anti-seize and anti-seize compound Use: Equipment lubrication and assembly compound.	Manufacturer/Supplier: JET-LUBE, INC. Address: 4849 Homestead Rd., Ste. #232 Houston, TX, 77028 USA Phone: 713-670-5700 Emergency Phone: 713-670-5700 Fax: 713-678-4604 Chemtrec 24 hours (USA): 800-424-9300 Outside the USA: 703-527-3887
---	---

Hazardous Components	CAS No.	Wt%	OSHA PEL	ACGIH TLV	Other Limits of Exposure
Petroleum oil	64742570/64742525	70-100	Oil mist TWA-5mg/M ³ 10mg/M ³	N/A	STEL: 10mg/M ³
Nonhazardous Blend	1317335/68953582 68411461	20-30		10mg/M ³	UN

Main Hazards—Health Effects

Eyes: May cause irritation. **Inhalation:** Viscous nature may block breathing passages if inhaled. **Ingestion:** May cause diarrhea.
Skin: Possible rash for persons with persensitivity.

Eyes: Flush with water until all residual material is gone. If irritation persists, seek medical help. **Inhalation:** Clear air passage. If respiratory difficulty continues, seek medical help. **Ingestion:** Wash out mouth immediately. Consult physician. **Skin:** Wash thoroughly with hand cleanser, followed by soap & water. Contaminated clothing should be dry cleaned before reuse.

Extinguishing Media: Foam, dry powder, Halon®, carbon dioxide, sand, earth & water mist. **Unsuitable Extinguishing Media:** Water jet.
Protective Equipment for Fire fighting: Self-contained breathing apparatus.

Personal Precautions: Wear gloves & protective overalls. **Environmental Precautions:** Do not allow it to enter drains. **Spillage:** Scrape up bulk, then wipe up remainder with cloth. To prevent walking hazard, pick up remaining residue with diatomaceous earth.

Handling: No special handling precautions necessary. **Storage:** Do not store at elevated temperatures.

Respiratory Protection: None needed. **Hand Protection:** Protective gloves for hypersensitive persons. **Eye Protection:** Glasses, if applied to parts in motion. **Body Protection:** Overalls.

Physical State: Semisolid paste **Color:** Black **Odor:** Petroleum **pH:** Neutral **Boiling Range/Point °F (°C):** >700 (371)
Melting Point °F (°C): None **Flash Point (COC) °F (°C):** 560 (293) **Propellant Flash Point °F (°C):** 76 (-60) **OAR Value:** 5 (aerosol)
Autoignition Temperature °F (°C): >680 (360) **Explosive Properties:** LEL: 0.9% UEL: 7% **Evaporation Rate (Butyl Acetate):** <0.01
Partition Coefficient (Log Pow): N/A **Vapor Pressure (kPa):** <0.01 **Percent Volatiles:** Nil **Density (g/cm³):** 1.06
Flammability: Not flammable at ambient temperatures (aerosol only). **Oxidizing Properties:** None **Water Solubility:** Nil **Vapor Density:** >5

Stability: Chemically stable under normal conditions. No photoreactive agents. **Conditions to Avoid:** Powerful sources of ignition & extreme temps. **Materials to Avoid:** Strong inorganic & organic acids, oxidizing agents. **Hazardous Decomposition Products:** Burning generates smoke, airborne soot, hydrocarbons & oxides of carbon, sulfur & nitrogen. Residue mainly comprised of soot & mineral oxides.

Acute Toxicity: Not known. **Irritancy—Skin:** Very mild. **Skin Sensitization:** Not known. **Subacute/Sub-chronic Toxicity:** Not known.
Genotoxicity: None known. **Chronic Toxicity:** None known. **California Prop 65:** N/A **Carcinogen:** NTP: No IARC: No **OSHA:** No
EC Class (67/548/EEC): No **Allergens:** None known. **LC-50:** >2000mg/kg-(extrapolated from component data) **LD-50:** N/A

Possible Effects: May generate oil fractions that could act as a marine pollutant, but is unlikely.

Behavior: Relatively well behaved. Bioaccumulation potential nil. **Environmental Fate:** Highly unlikely to cause notable contamination.

Product Disposal: Do not incinerate. Contact waste disposal company or local authority for advice.

Container Disposal: Pails without liner—see Product Disposal section above. Pails with plastic liner—pail may only be disposed of via standard waste disposal services, recycled or reused. Liner—see Product Disposal section above.

Not classified as hazardous for transport. **D.O.T.:** Nonhazardous **UN No.:** Nonhazardous

Air Transport (ICAO & IATA): Nonhazardous **Sea Transport (IMO & IMDG):** Nonhazardous

Road & Rail Transport (ADR/RID): Nonhazardous

Labeling Information: None needed **EC Annex 1 Classification:** Not Applicable. **R Phrases:** R22—harmful if swallowed.

S Phrases: None applicable, as known. **Ozone Depleting Chemicals:** Not applicable. **TSCA:** All components are listed.

WHMIS (Canada): Not controlled. **Canadian DSL:** All components listed. **SARA 311/312:** None **TSCA 12B Components:** None

40 CFR Part 372 (SARA Section 313): N/A **CERCLA:** Nonhazardous **RCRA Hazard Class:** Nonhazardous

SDS first issued. SDS data revised. **New Jersey Right To Know:** See Section II

Signature: 
 Prepared by: Donald A. Oldiges
 Date Issued: September 21, 2009

As of issue date, the information contained herein is accurate and reliable to the best of JET-LUBE'S knowledge. JET-LUBE® does not warrant or guarantee its accuracy or reliability and shall not be liable for any loss or damage arising out of the use thereof. It is the user's responsibility to satisfy itself that the information offered for its consideration is suitable for its particular use.

LEGEND

- I. IDENTIFICATION OF THE SUBSTANCE/PREPARATION AND COMPANY
- II. COMPOSITION INFORMATION ON INGREDIENTS
- III. HAZARDS IDENTIFICATION
- IV. FIRST AID MEASURES
- V. FIRE FIGHTING MEASURES
- VI. ACCIDENTAL RELEASE MEASURES
- VII. HANDLING AND STORAGE
- VIII. EXPOSURE CONTROL/PERSONAL PROTECTION
- IX. PHYSICAL AND CHEMICAL PROPERTIES
- X. STABILITY AND REACTIVITY
- XI. TOXICOLOGICAL INFORMATION
- XII. ECOLOGICAL INFORMATION
- XIII. WASTE DISPOSAL
- XIV. TRANSPORT INFORMATION
- XV. REGULATORY INFORMATION
- XVI. OTHER INFORMATION

HMIS SYMBOL

HEALTH	1
FLAMMABILITY	1
REACTIVITY	0
PPI	B

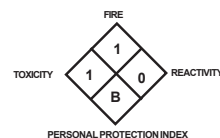

Safety data sheet for product

1. PRODUCT AND COMPANY IDENTIFICATION

- Product name: Lithium ion rechargeable battery cell
- Product code: None
(All models Sanyo manufactured and whose capacity is less than or equal to 5.4Ah, excluding the cell whose shape is prismatic and two or more side of short / middle / long side excess 12mm/85mm/110mm.)
- Company name: Sanyo Electric Co., Ltd.
- Address: 222-1, Kaminaizen, Sumoto City, Hyogo, Japan
- Telephone number: +81-799-24-4111
- Fax number: +81-799-23-2879
- Emergency telephone number: [Weekday] +81-799-23-3931 [Night and holiday] +81-799-24-4131

2. COMPOSITION / INFORMATION ON INGREDIENTS

- Substance or preparation: Preparation
- Information about the chemical nature of product: *1

Portion	Material name	Concentration range (wt %)
Positive electrode	Lithium transition metal oxidate (Li[M] _m [O] _n *2)	20~60
Positive electrode's base	Aluminum	1~10
Negative electrode	Carbon	10~30
Negative electrode's base	Copper	1~15
Electrolyte	Organic electrolyte principally involves ester carbonate	5~25
Outer case	Aluminum, iron, aluminum laminated plastic	1~30

*1 Not every product includes all of these materials.

*2 The letter M means transition metal and candidates of M are Co, Mn, Ni and Al. One compound includes one or more of these metals and one product includes one or more of the compounds. The letter m and n means the number of atoms.

3. HAZARDS IDENTIFICATION

For the battery cell, chemical materials are stored in a hermetically sealed metal or metal laminated plastic case, designed to withstand temperatures and pressures encountered during normal use. As a result, during normal use, there is no physical danger of ignition or explosion and chemical danger of hazardous materials' leakage.

However, if exposed to a fire, added mechanical shocks, decomposed, added electric stress by miss-use, the gas release vent will be operated. The battery cell case will be breached at the extreme, hazardous materials may be released.

Moreover, if heated strongly by the surrounding fire, acrid gas may be emitted.

- Most important hazard and effects

Human health effects:

Inhalation: The steam of the electrolyte has an anesthesia action and stimulates a respiratory tract.

Skin contact: The steam of the electrolyte stimulates a skin. The electrolyte skin contact causes a sore and stimulation on the skin.

Eye contact: The steam of the electrolyte stimulates eyes. The electrolyte eye contact causes a sore and stimulation on the eye. Especially, substance that causes a strong inflammation of the eyes is contained.

Environmental effects: Since a battery cell remains in the environment, do not throw out it into the environment.

- Specific hazards:

If the electrolyte contacts with water, it will generate detrimental hydrogen fluoride.

Since the leaked electrolyte is inflammable liquid, do not bring close to fire.

4. FIRST-AID MEASURES

Spilled internal cell materials

- Inhalation:
Make the victim blow his/her nose, gargle. Seek medical attention if necessary.
- Skin contact:
Remove contaminated clothes and shoes immediately. Wash extraneous matter or contact region with soap and plenty of water immediately.
- Eye contact:
Do not rub one's eyes. Immediately flush eyes with water continuously for at least 15 minutes. Seek medical attention immediately.

A battery cell and spilled internal cell materials

- Ingestion:
Make the victim vomit. When it is impossible or the feeling is not well after vomiting, seek medical attention.
-

5. FIRE-FIGHTING MEASURE

- Suitable extinguishing media: Plenty of water, carbon dioxide gas, nitrogen gas, chemical powder fire extinguishing medium and fire foam.
 - Specific hazards: Corrosive gas may be emitted during fire.
 - Specific methods of fire-fighting: When the battery burns with other combustibles simultaneously, take fire-extinguishing method which correspond to the combustibles. Extinguish a fire from the windward as much as possible.
 - Special protective equipment for firefighters:
 - Respiratory protection: Respiratory equipment of a gas cylinder style or protection-against-dust mask
 - Hand protection: Protective gloves
 - Eye protection: Goggle or protective glasses designed to protect against liquid splashes
 - Skin and body protection: Protective cloth
-

6. ACCIDENTAL RELEASE MEASURES

Spilled internal cell materials, such as electrolyte leaked from a battery cell, are carefully dealt with according to the followings.

- Precautions for human body:
Remove spilled materials with protective equipment (protective glasses and protective gloves). Do not inhale the gas as much as possible. Moreover, avoid touching with as much as possible.
 - Environmental precautions: Do not throw out into the environment.
 - Method of cleaning up: The spilled solids are put into a container. The leaked place is wiped off with dry cloth.
 - Prevention of secondary hazards: Avoid re-scattering. Do not bring the collected materials close to fire.
-

7. HANDLING AND STORAGE

- Handling suggestions
 - Do not connect the positive terminal to the negative terminal with electrical wire or chain.
 - Avoid polarity reverse connection when installing the battery to an instrument.
 - Do not wet the battery with water, seawater, drink or acid; or expose to strong oxidizer.
 - Do not damage or remove the external tube.
 - Keep the battery away from heat and fire.
 - Do not disassemble or reconstruct the battery; or solder the battery directly.
 - Do not give a mechanical shock or deform.
 - Do not use unauthorized charger or other charging method. Terminate charging when the charging process doesn't end within specified time.
- Storage
 - Do not store the battery with metalware, water, seawater, strong acid or strong oxidizer.
 - Make the charge amount 30~50% then store at room temperature or less (temperature= -20~35 degree C) in a dry (humidity: 45~85%) place. Avoid direct sunlight, high temperature, and high humidity.
 - Use insulative and adequately strong packaging material to prevent short circuit between positive and negative terminal when the packaging breaks during normal handling. Do not use conductive or easy to break packaging material.

8. EXPOSURE CONTROLS / PERSONAL PROTECTION (WHEN THE ELECTROLYTE LEAKS)

- Control parameters
ACGIH has not been mentioned control parameter of electrolyte.
 - Personal protective equipment
Respiratory protection: Respirator with air cylinder, dust mask
Hand protection: Protective gloves
Eye protection: Goggle or protective glasses designed to protect against liquid splashes
Skin and body protection: Working clothes with long sleeve and long trousers
-

9. PHYSICAL AND CHEMICAL PROPERTIES

- Appearance
Physical state: Solid
Form: Cylindrical or Prismatic or Pouch (laminated)
Color: Metallic color or black(without tube if it has tube)
Odor: No odor
-

10. STABILITY AND REACTIVITY

- Stability: Stable under normal use
 - Hazardous reactions occurring under specific conditions
 - Conditions to avoid: When a battery cell is exposed to an external short-circuit, crushes, deformation, high temperature above 100 degree C, it will be the cause of heat generation and ignition. Direct sunlight and high humidity.
 - Materials to avoid: Conductive materials, water, seawater, strong oxidizers and strong acids.
 - Hazardous decomposition products: Acrid or harmful gas is emitted during fire.
-

11. TOXICOLOGICAL INFORMATION

Organic Electrolyte

- Acute toxicity:
LD₅₀, oral - Rat 2,000mg/kg or more
 - Irritating nature: Irritative to skin and eye
-

12. ECOLOGICAL INFORMATION

- Persistence/degradability:
Since a battery cell and the internal materials remain in the environment, do not bury or throw out into the environment.
-

13. DISPOSAL CONSIDERATIONS

- Recommended methods for safe and environmentally preferred disposal:

Product (waste from residues)

Specified collection or disposal of lithium ion battery is required by the law like as "battery control law" in several nations. Collection or recycle of the battery is mainly imposed on battery's manufacturer or importer in the nations recycle is required.

Contaminated packaging

Neither a container nor packing is contaminated during normal use. When internal materials leaked from a battery cell contaminates, dispose as industrial wastes subject to special control.

14. TRANSPORT INFORMATION

In the case of transportation, avoid exposure to high temperature and prevent the formation of any condensation. Take in a cargo of them without falling, dropping and breakage. Prevent collapse of cargo piles and wet by rain. The container must be handled carefully. Do not give shocks that result in a mark of hitting on a cell. Please refer to Section 7-HANDLING AND STORAGE also.

UN regulation

- UN number: 3480 (3481 when the battery is contained in equipment or packed with equipment)
- Proper shipping name:
Lithium ion batteries ("lithium ion batteries contained in equipment" or "lithium ion batteries packed with equipment")
- Class: 9 *
- Packing group: II *

** However this product is defined as above, it is **not** recognized as "DANGEROUS GOODS" or is treated as almost non-DANGEROUS GOODS when its transport condition accords with instructions or provisions depend on region and transportation mode.*

About the instructions or provisions, please see descriptions in box brackets of following regulations.

Regulation depends on region and transportation mode

- Worldwide, air transportation:
IATA-DGR [As non-DANGEROUS GOODS: "packing instruction 965 section II" /
Almost as above however displayed as DANGEROUS GOODS: "packing instruction 965 section IB"]
(When batteries are packaged with equipments or contained in equipments, refer packing instruction 966 or 967 instead of 965.)
- Worldwide, sea transportation:
IMO-IMDG Code [special provision 188]
- Europe, road transportation:
ADR [special provision 188]

15. REGULATORY INFORMATION

- Regulations specifically applicable to the product:
Wastes Disposal and Public Cleaning Law [Japan]
Law for Promotion of Effective Utilization of resources [Japan]
US Department of Transportation 49 Code of Federal Regulations [USA]

** About overlapping regulations, please refer to Section 14-TRANSPORT INFORMATION.*

16. OTHER INFORMATION

- This safety data sheet is offered an agency who handles this product to handle it safely.
- The agency should utilize this safety data sheet effectively (put it up, educate person in charge) and take proper measures.
- **The information contained in this Safety data sheet is based on the present state of knowledge and current legislation.**
- This safety data sheet provides guidance on health, safety and environmental aspects of the product and should not be construed as any guarantee of technical performance or suitability for particular applications.

Reference

Dangerous Goods Regulations – 54th Edition Effective 1 January 2013: International Air Transport Association (IATA)
IMDG Code – 2012 Edition: International Maritime Organization (IMO)
The European Agreement concerning the International Carriage of Dangerous Goods by Road – 2013:
The United Nations Economic Commission for Europe (UNECE)

BATTERY SPECIFICATIONS

Nominal Voltage	18V		
Typical Capacity	4 Ah	5.5 Ah	8 Ah
Energy	72Wh	99Wh	144Wh
Chemical system	Lithium Transition Metal Oxide (Li[M]m[O]n)		
Designed for Recharge	Yes		

⚠ WARNING:

Only use TorcUP approved batteries.
 Do not allow battery packs to come in contact with water.
 Do Not expose battery packs to heat or fire.
 Discharge battery pack before disposal. Prevent contacts from short-circuiting.
 Do not dispose of battery packs with household waste. Observe national regulations on proper disposal.

CHARGER SPECIFICATIONS	
Input	110v or 220v
Mains frequency	50-60 Hz
Output	18 VDC
Charge time	30 minutes at 1.5 Ah

VIBRATION INFORMATION (ALL TOOL SIZES)

Vibration	< 2.5 M/s ²
Uncertainty	1.5 M/s ²
In accordance with EN 60745	

WARNING: The vibration emission value during actual use of the power tool can differ from the declared value depending on ways in which the tool is used.

NOISE INFORMATION (ALL TOOL SIZES)

LpA / KpA	dB(A)	76 / 3
LWA / KWA	dB(A)	87 / 3
In accordance with EN 60745		

🔊 WARNING: Wear ear protection when sound pressure is over: 80dB(A)

ENVIRONMENTAL SPECIFICATIONS**⚠ CAUTION!**

Only operate the Volta Series Battery wrenches if the following storage and operations conditions have been met.

TEMPERATURE RANGE	FAHRENHEIT	CELSIUS
Operating	5-122	-15 - 50
Charging	32-122	0 - 50
Storage	50 - 86	10 - 30
Humidity	10% - 90% non condensing	
Required Operating Conditions	Non Explosive Atmosphere. Dry Location	

